

CLD RiseMaster HE Barrier

CLD Auto Access Barrier System



Description

CLD RiseMaster HE Barrier is a fully autonomous off grid, solar powered automatic boom arm barrier system. It is available in both surface mount version - free standing and rapidly deployable - as well as permanent version, and is incorporated with photovoltaic panels. No road crossing cabling are required.

The RiseMaster HE can power access control systems such as intercoms, radio transmitters and other equipment to be compliant with Safety Force Test Compliant to EN 12453:2017. FenceSafe Battery Container allows static equilibrium of the system and housing of the batteries to be combined within the same container.



Find out more
Scan for more information

Features

24/7 365 Off Grid Solar
Autonomy

Zero Carbon Emissions over
10 Year Life Cycle

No road crossing cabling
required

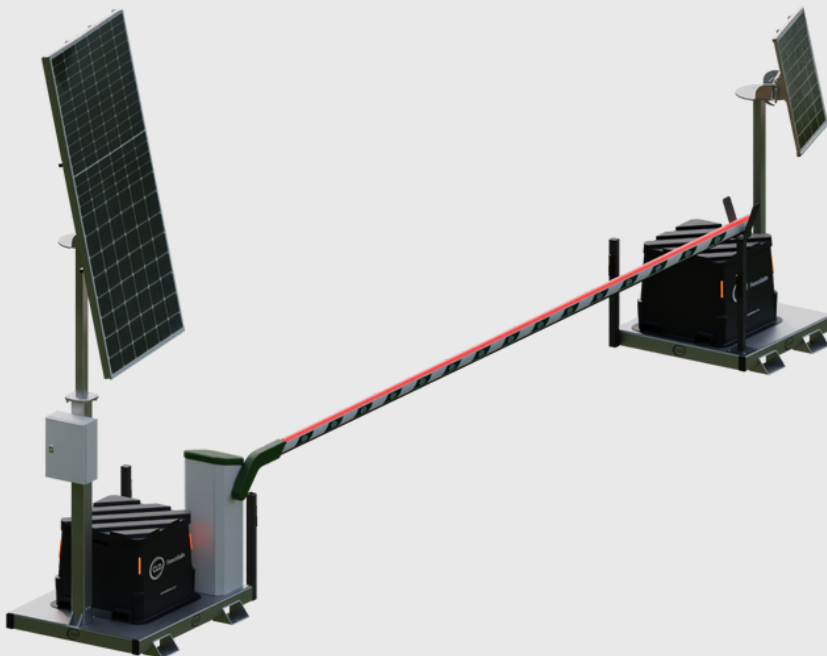

Exploded view of post and fixing details for the CLD RiseMaster HE
This product has additional features not demonstrated for security reasons



Patent Pending No. 2304787.1.

cld-systems.com

CLD RiseMaster HE Barrier

CLD Auto Access Barrier System

Product Technical Information

Standard	EN 12453:2017 UKCA Declaration of Conformity (UK) CE Declaration of Conformity (EU) CSA Declaration of Conformity (North American) UL Declaration of Conformity (USA)
Description	Perimeter/car park 24/7 365 Off Grid Solar Autonomy barrier system.
Daily Cycles	3000 Daily Cycles Ultra Variant
Power supply requirements	Off-grid solar powered: No electrical supply required
Max span dimension	26.2ft
Pole Dimensions	9.8ft to 26.2ft
Finish	Galvanised / powder coated
Unit weight	939lbs Primary Platform, 307lbs Secondary Platform
Barrier Installation	Not applicable - free standing on-ground
Cabinet	Mild steel - removable sections for servicing access
Locking	Mechanical automatic
Warranty	12 months return to factory for purchased systems. Continuous site warranty for hired systems
Barrier construction	Mild steel cabinet, with aluminum boom arm profile. Rubber buffer profiles fitted to both the upper and lower faces of the aluminum boom arm.
Additional features	Powered via the on-board solar system: 4G WiFi connectivity WiFi access control: intercoms, radio transmitters, other equipment Wired safety devices to CAT2 accreditation. Remote Support & First Line Response Continuous Powering of LED Boom Strip Lights (red/green) Intelligent Force Limitation

System Details

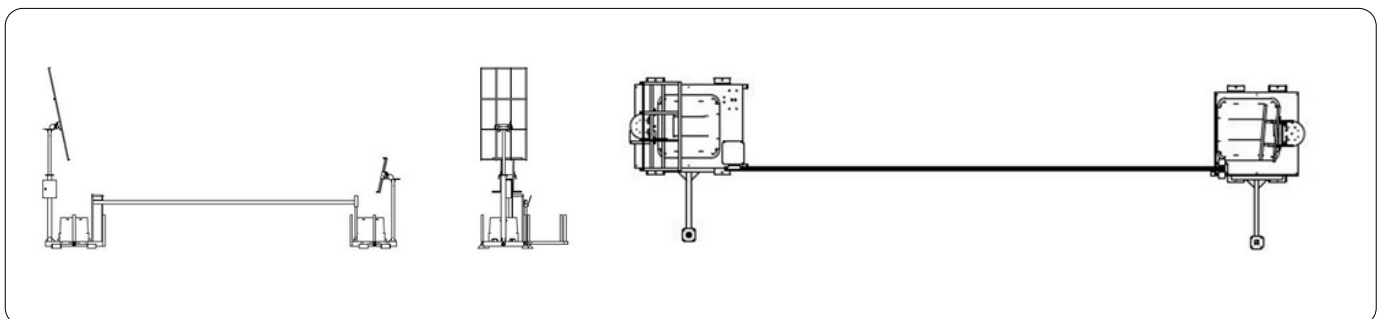

Disclaimer

Automatic barriers should be installed and commissioned in accordance with EN 12453:2017. Every care has been taken to ensure that all information provided on this data sheet is accurate. CLD Systems Ltd reserves the right to change product specification at any time. Please ensure that you have the latest information which can be found on our website or by contacting our team.

Document Reference - CLD_RiseMaster HE_DS_20230421